

jumpzylla  
fitness



# INSTALLATION MANUAL

ONE BOUNCE AT A TIME

# jumpzylla fitness

**When it comes to our customers  
we don't monkey around!**

## **GET IN TOUCH WITH US:**



**[contact@jumpzylla.com](mailto:contact@jumpzylla.com)**



**[instagram.com/jumpzylla/](https://www.instagram.com/jumpzylla/)**



**[facebook.com/jumpzylla](https://www.facebook.com/jumpzylla)**

# DISCLAIMER

Please read the instructions before starting the installation process. Incorrect installation might damage the trampoline and cause injuries!

- Max user weight limit: check size chart.
- Not suitable for children under 36 months – small parts, choking hazard.
- The trampoline must be set up by an adult following the instructions.
- Consult your physician before beginning any exercise or diet program; if you feel dizziness, nausea, chest pain, back pain or other abnormal symptoms, STOP your workout and CONSULT A PHYSICIAN IMMEDIATELY!
- Empty pockets and hands before jumping.
- Always jump in the middle of the mat.
- Do not eat while jumping. It is advisable not to bounce immediately after a meal.
- Do not use if you notice any defects or broken parts.

# SAFETY GUIDELINES

Recommended for adults and teens. Children need to be supervised when using the product.

- Keep your bounce low: Avoid bouncing too high to maintain control.
- Always aim to land in the center of the trampoline.
- Overhead clearance: Make sure there's at least 10 feet (3 meters) of space above the trampoline. Keep away from wires, ceiling fans, or any other hazards.
- Clear space around the trampoline: Ensure there's at least 6 feet (1.8 meters) of space on all sides, away from walls, furniture, or other structures.
- Check under the trampoline: Remove any objects from underneath to prevent accidents.
- Daytime use recommended: Avoid using the trampoline in the dark. If necessary, use adequate lighting.
- One at a time: Only one person should jump at a time to prevent injuries.
- Use indoors or outdoors.
- Any modifications made by the consumer to the original trampoline shall be carried out according to the instructions of the manufacturer.

# OUR BELIEVES

The steps we follow when it comes to our products and clients!



FROM IDEA

## THE IDEA

We always try to come up with the best and most innovative ideas

## THE PLAN

We organize and write everything down. We build a solid fail proof plan.



TO PLAN



TO ACTION

## THE ACTION

We apply the highest production standards in our factories.



TO EXTENSIVE TESTING

## THE TESTING

We make sure each and every product is up to standards and completely safe to use



TO CLIENT

## IF OUR CLIENTS ARE HAPPY, WE ARE HAPPY

Our goal is to offer our clients the best and safest products.

Proud owner of a JUMPZYLLA FITNESS Trampoline? Here is what you need to know:



Make sure to properly run a complete check-up of the trampoline (main parts, frame, suspension system, mat, ) at the beginning of each season and every 2 weeks!



Do not jump with sharp object in your hands or pockets. Do not drink eat or smoke while using the trampoline.



Check all nuts and bolts for tightness and tighten when required.



Do not flip on the fitness trampoline. Do not attempt dangerous tricks.



Always supervise children while jumping.



Do not use the fitness trampoline if you are injured.



Do not use the fitness trampoline if you are pregnant.

















Do not jump 2 people in the same time.



[contact@jumpzyl.com](mailto:contact@jumpzyl.com)

# PART LIST

You are the proud owner of a JUMPZYLLA FITNESS trampoline!  
Here is what you will find in your package:

			 <b>40INCH</b>	 <b>48INCH</b>
		<b>MAX WEIGHT</b>	<b>450LBS</b>	<b>550LBS</b>
<b>A</b>		Main frame with Jumping Mat and Bungee Cords	1pc	1pc
<b>B</b>		Bungee Cord (pre-installed)	28pc	36pc
<b>C</b>		Leg with Cap	6pc	8pc
<b>D</b>		Handrail Leg -Right	1pc	1pc
<b>E</b>		Handrail Leg -Left	1pc	1pc
<b>F</b>		Handrail Bar with Foam	1pc	1pc
<b>G</b>		Handrail Support - Right	1pc	1pc
<b>H</b>		Handrail Support - Left	1pc	1pc
<b>I</b>		Secure Pin	1pc	1pc
<b>J</b>		Bar Adjustment Knob	2pc	2pc
<b>K</b>		Leg Adjustment Knob	6pc	6pc
<b>L</b>		Bungee Installation Tool	1pc	1pc
<b>M</b>		Extra Foot Pad	3pc	3pc

## ATTENTION



If you notice any pieces missing please don't hesitate to contact us. We will solve any issues and make sure you will be able to use the Jumpzylla fitness trampoline as soon as possible!

 [contact@jumpzylla.com](mailto:contact@jumpzylla.com)

# CONGRATULATIONS!

You made a great choice with Jumpzyl! Now, let's get started and put this trampoline together.

## STEP 1

- Unfold the frame and mat:** Take the trampoline's frame and mat (A) and unfold them.
- Lay it flat:** Place the trampoline flat on the ground, with the mat side facing down.
- Press down:** Apply pressure to the frame until it stays flat on the surface.

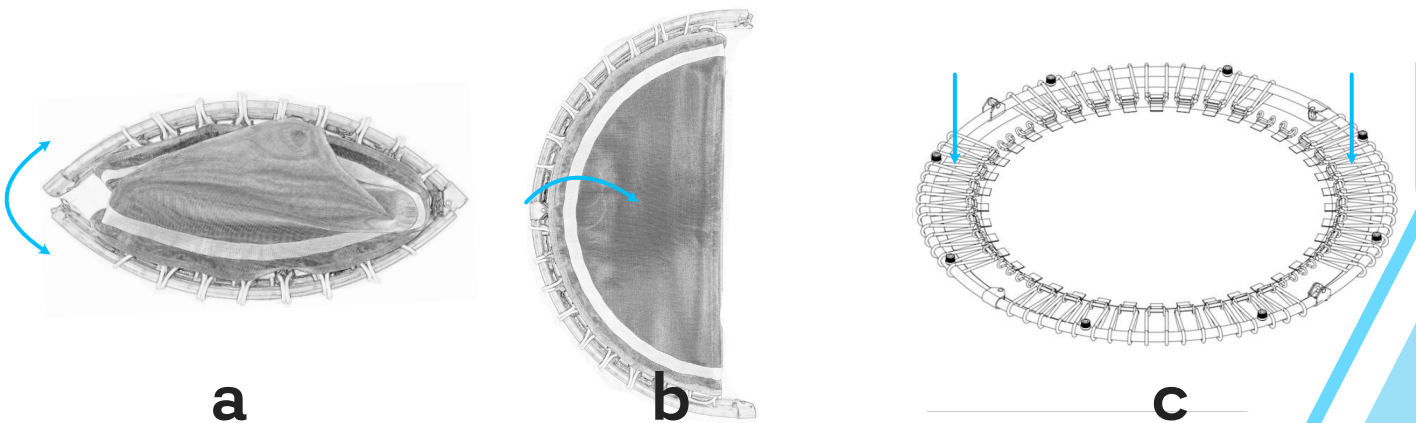

## STEP 2

**Secure the frame:** Insert the secure pin (I) through the aligned holes in the frame to lock the sections securely in place.

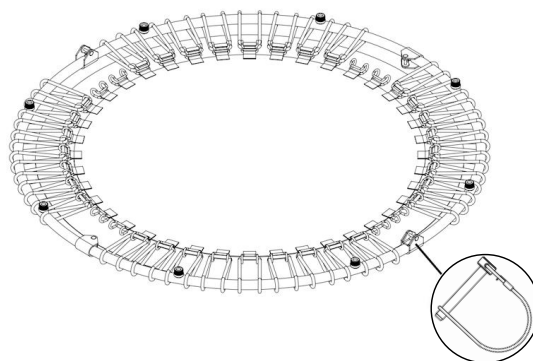

### STEP 3

**If any of the bungee cords come loose:** Use the tool labeled (L) to help guide the rope back into place easily.

Make sure the bungee cords are securely in place all around the trampoline.

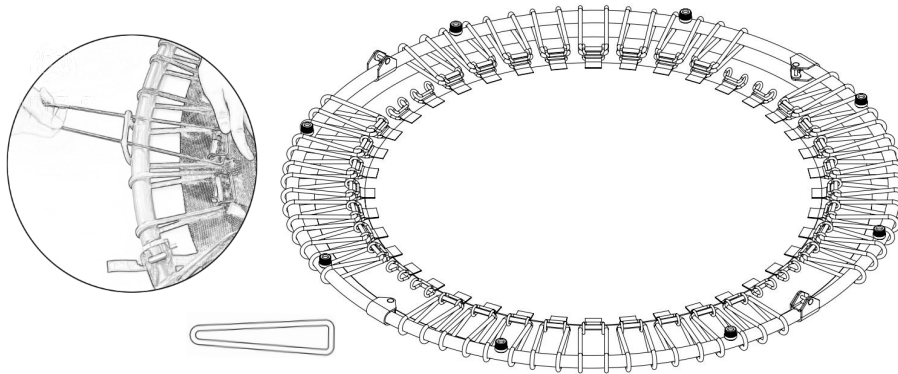

### STEP 4

Screw each leg (C) tightly into the leg sockets on the trampoline frame.

Make sure every leg is firmly secured and the leg caps are screwed tightly to prevent the trampoline from wobbling. Ensure all legs are flat and evenly positioned on the ground before use for stability and safety

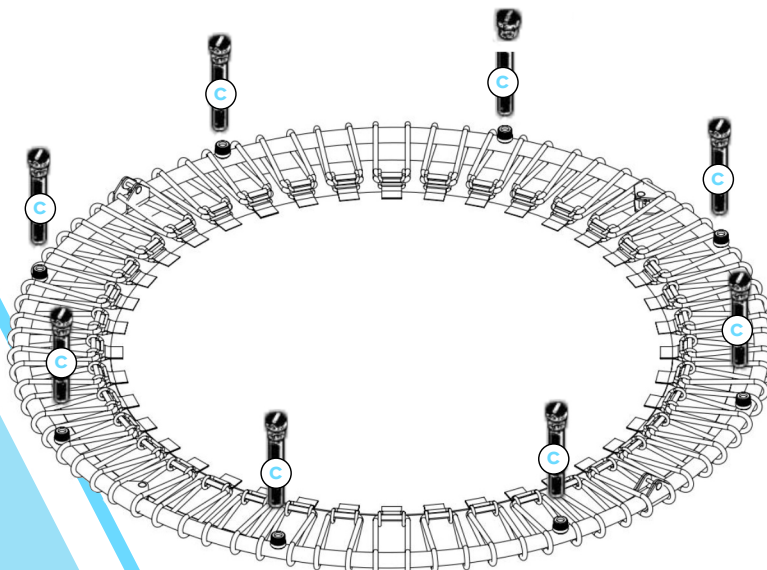

## STEP 5

Lift the trampoline into a standing position. Attach the handrail legs (**D and E**) to the two front legs of the trampoline (without the leg caps).

Use the adjustment knob (**K**) to secure the handrail legs, but do not tighten the screws completely until the next step.

After securing the handrail legs, place the leg caps back onto the handrail legs.

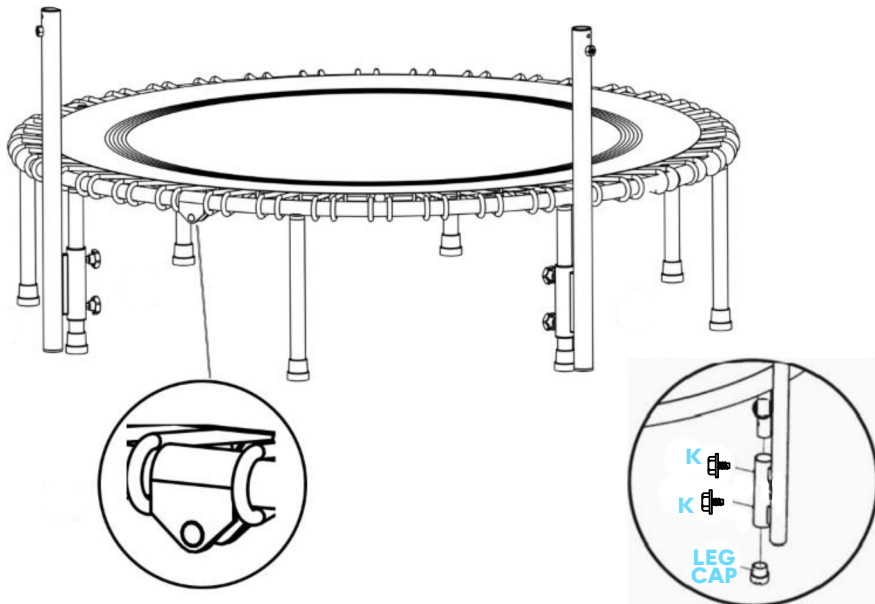

## STEP 6

Attach the Handrail Supports (**G and H**) to each side of the Handlebar (**F**). Secure them tightly using the Bar Adjustment Knobs (**J**) on each side.

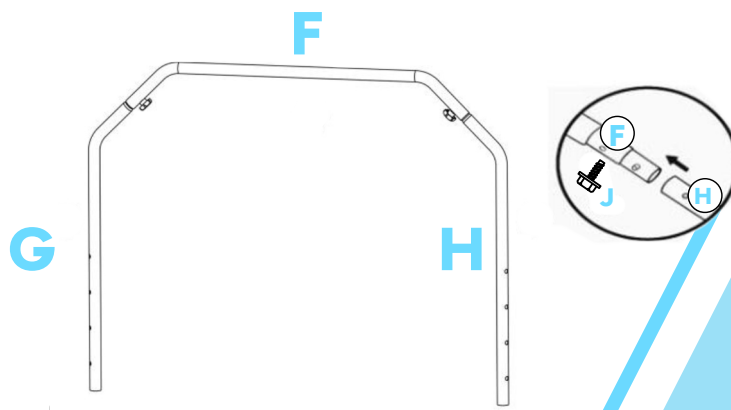

## STEP 7

Connect the assembled handlebar to the Handrail Leg Supports (**D and A**)  
Adjust the height as you please and secure with Adjustment Knob (**K**).

Make sure all Legs, Leg Caps, and Knobs are tightly screwed, and ensure that the legs are flat on the ground to avoid any wobbling during use.

### OPTIONAL!

The foot pads are only used to adjust the balance of the trampoline. They are not required for installation on all legs.

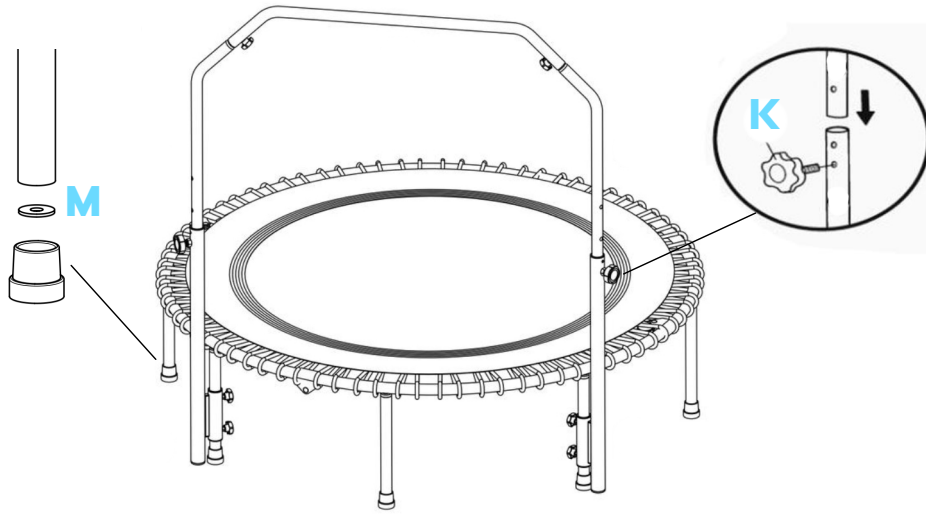

## STEP 8

PRO TIP:

Hook the 4 ropes on the side of mat into the steel buckle, to make the cover flat

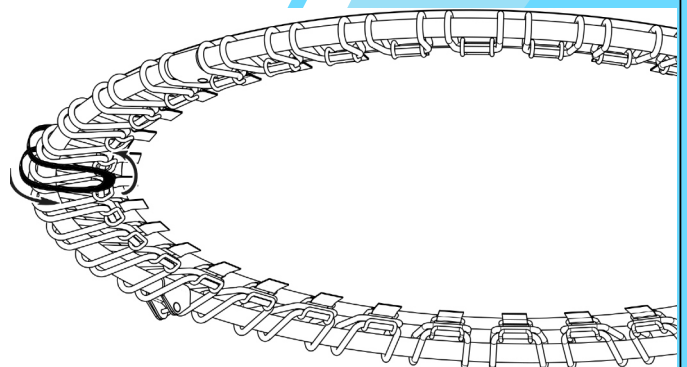
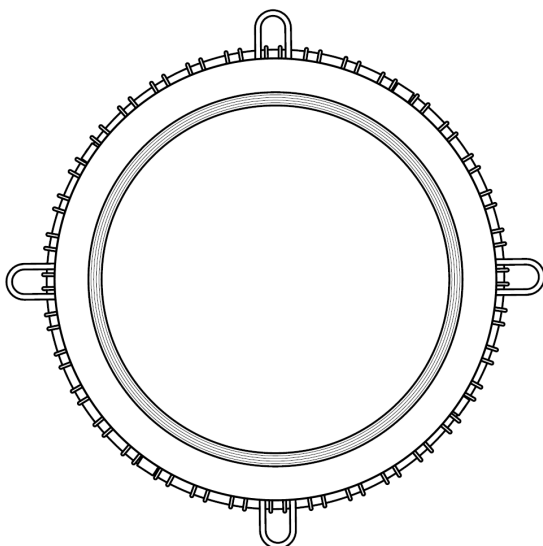

# ATTENTION



**If you notice any pieces missing please don't hesitate to contact us. We will solve any issues and make sure you will be able to use the Jumpzylla fitness trampoline as soon as possible!**

 [\*\*contact@jumpzylla.com\*\*](mailto:contact@jumpzylla.com)

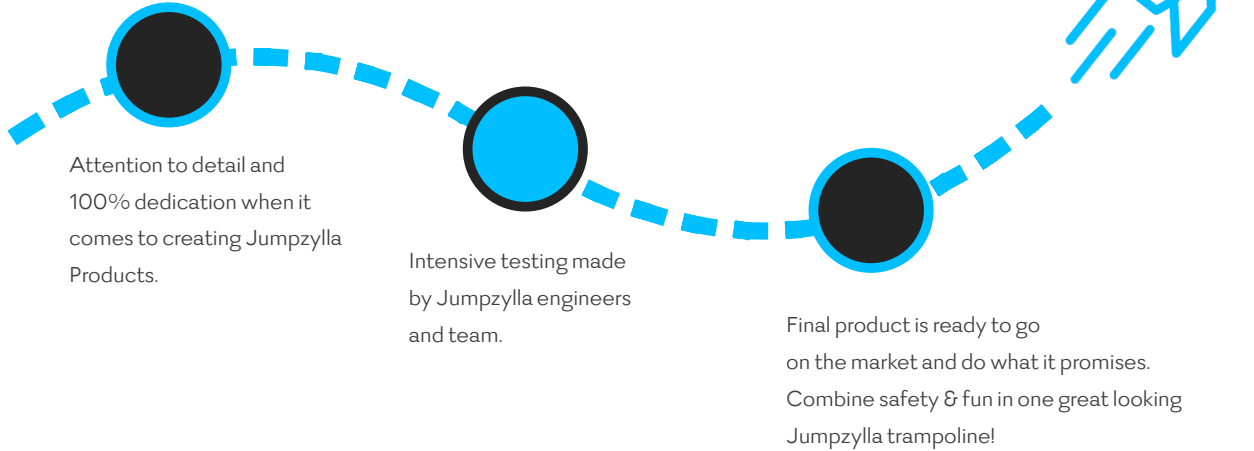

## GET IN TOUCH WITH US:

 [contact@jumpzylla.com](mailto:contact@jumpzylla.com)

 [instagram.com/jumpzylla/](https://www.instagram.com/jumpzylla/)

 [facebook.com/jumpzylla](https://www.facebook.com/jumpzylla)

**Thank you for choosing  
JUMPZYLLA FITNESS!**

Don't hesitate to contact us if you have any questions or simply want to say Hi!